

**CAUTION:** 1. For your safety read this manual completely before installation or servicing.  
2. Before installing or servicing, please ensure the line pressure has been relieved, and any hazardous fluids have been drained or purged from the system.  
3. Ensure that all Lockout and Tagout procedures for the system have been properly implemented.

1. **USE:**

- 1.1 A-T Controls' Power-Seal High Performance Butterfly Valves are available in lug and wafer style designs and are compatible with ANSI 150# and 300# flanges.
- 1.2 Maximum results and optimum valve life can be maintained under normal service conditions and in accordance with pressure/temperature ratings and corrosion data chart.
- 1.3 The Power-Seal High Performance Butterfly Valves come in three seat designs; the soft seat (PS Series), fire-safe (PF Series), and metal seat (PM/PH Series). All designs are covered in this manual

2. **GENERAL INFORMATION FOR INSTALLATION:**

A-T Controls' Power-Seal High Performance Butterfly Valves are designed to mount between ANSI 150 and ANSI 300 pipe flanges that meet ANSI B16.5 flange specification for valves 2"-24". For valves 26"-48" the valves are designed to mount between ANSI B16.47-Series A flanges.

**CAUTION: Physical injury and property damage may occur if the valve is not operating in the appropriate service conditions.**

- 2.1 Check the tag on the valve to ensure that the valve's material, class, and operating pressure are suitable for the application.
- 2.2 A-T Controls' Power-Seal High Performance Butterfly Valves are bi-directional, however they are marked with a preferred flow direction. Mounting the valve with the retainer ring upstream can reduce the wear on the valve and may extend the service life.
- 2.3 The valve can be mounted in any position, provided that the handle, gear, or actuator has proper clearance. Also be sure that the operator can be easily accessed and the open/close indicator can be viewed. If the gear is equipped with a chain wheel the valve should be mounted in a way so that the chain does not come in contact with the valve or pipeline. If the process media has a tendency to buildup, contains solids, or is an abrasive material it is recommended to mount the valve with the stem in the horizontal position. Doing so may improve the service life of the valve.
- 2.4 Before installing the valves, the pipe must be flushed clean of dirt, burrs and welding residues. Failure to do so may result in damage to the seats and sealing surfaces.
- 2.5 The pipe must be free from tension and in proper alignment.
- 2.6 A-T Controls' Power-Seal High Performance Butterfly Valves are designed to work with gaskets that meet requirements of ASME B16.21.
- 2.7 Before installing valves check to ensure that all flange seals are free from defects.
- 2.8 Before installing valves check to ensure that there is proper clearance for the disc to be able to fully open and close without being obstructed. This is especially important when using larger than sch. 40 pipes as the clearances become smaller. See catalog for dimensions.
- 2.9 The operator should be installed on the valve prior to installing the valve in the pipeline. This is to ensure that the limits are set so that the disc is aligned properly. Also check that the valve is in the closed position when operating the valve clockwise and is in the open position when operating counter-clockwise.
- 2.10 The valve should be installed in the pipeline in the closed position to prevent damage to the disc.
- 2.11 Install the valve in the pipeline and tighten bolts uniformly in a star pattern.

### 3. MANUAL OPERATION:

**CAUTION:** A-T Controls recommends a manual gear operator for all valves 6" and larger.

**HANDLE:** To **OPEN** the valve; squeeze the handle to unlock it and turn it in the counter-clockwise direction. The handle can be locked in at 10 degree increments to adjust the flow. The valve will be locked into the 90 degree marker and parallel to the pipeline when fully open.

To **CLOSE** the valve; squeeze the handle to unlock it and turn it in the clockwise direction. The handle can be locked in at 10 degree increments to adjust the flow. The valve will be locked into the 0 degree marker and perpendicular to the pipeline when fully closed.

**GEAR:** To **OPEN** the valve; turn the hand wheel counter-clockwise. The indicator will be pointing to the open position and stop rotating when fully opened. The flow can be adjusted by stopping the indicator anywhere between open and close.

To **CLOSE** the valve, turn the hand wheel clockwise. The indicator will be pointing to the close position and the hand wheel will stop rotating when fully closed. The flow can be adjusted by stopping the indicator anywhere between open and close.

### 4. AUTOMATED OPERATION:

A-T Controls' Power-Seal High Performance Butterfly Valves can be mounted with quarter turn actuators. Valves with actuators should be checked for proper valve stem alignment. Angular or linear misalignment may result in high operational torque and unnecessary wear on the valve stem. See the actuator IOM for information on operating and mounting the actuator.

### 5. DISASSEMBLY & CLEANING PROCEDURE:

5.1 Drain and make sure there is no pressure in the pipeline and take necessary precautions for the media in the pipeline.

5.2 Set valve to closed position and remove it from the pipeline.

5.3 Lay the valve flat on a clean and smooth surface. Be sure to take necessary precautions when opening and closing the valve so to not damage the disc.

#### *UPPER PACKING:*

5.4 Remove the bracket bolts (10) and washers (11).

5.5 Loosen the nuts (13) on the bottom of the packing gland studs (16) so that bracket can move up and down freely. Remove the nuts (13) on top of the belleville washer cover (14). Remove the cover (14) and belleville washers (15). Make sure to note the order of the washers for reassembly. Loosen nuts (13) on the bottom of the studs (16) until you are able to remove packing gland flange (17), gland (18), and bracket (12). If needed, remove studs (16).

5.6 Use packing extractors to remove packing (19). Use caution not to damage the stem and valve body. The packing must be replaced once removed.

#### *LOWER PACKING:*

5.7 Unscrew and remove bottom cover (26), and use packing extractors to remove packing (25). Use caution not to damage the stem and valve body

*METAL SEAT: (Figure 1)*

- 5.8 Remove clamp bolts (9) and clamps (8). Clamps (8) are replaced by clamp plates (6) on wafer valves and can also be removed by removing the clamp bolts (9).
- 5.9 Carefully remove the retainer ring (31), seat gaskets (4), and seat (30). Be careful not to damage any of the sealing surfaces. Once gaskets are removed they must be replaced with a new gasket.

*SOFT SEAT: (Figure 2)*

- 5.10 Remove clamp bolts (9) and clamps (8). Clamps (8) are replaced by clamp plates (6) on wafer valves and can also be removed by removing the clamp bolts (9).
- 5.11 Carefully remove the retainer ring (7), seat gaskets (4), seat ring (5) and seat (3). Be careful not to damage any of the sealing surfaces. Once gaskets are removed they must be replaced with a new gasket.

*FIRE-SAFE SEAT: (Figure 3)*

- 5.12 Remove clamp bolts (9) and clamps (8). Clamps (8) are replaced by clamp plates (6) on wafer valves and can also be removed by removing the clamp bolts (9).
- 5.13 Carefully remove the retainer ring (29), seat gaskets (4), secondary seat and gasket (28 & 27), seat ring (5) and seat (3). Be careful not to damage any of the sealing surfaces. Once gaskets are removed they must be replaced with a new gasket.

**6. ASSEMBLY:**

- 6.1 Make sure that all parts are clean before reassembling. **CAUTION:** If seats and packing have been removed be sure to install seats first to ensure that the disc lines up with the seats.

*METAL SEAT: (Figure 1)*

- 6.2 Install one seat gasket (4) in the valve body (1) and one seat gasket (4) in the retainer ring (31).
- 6.3 Install the seat (30) into the valve. See figure 1 for correct ordination of the seat.
- 6.4 Install the retainer ring (31). Insert clamps (6 & 8) and torque clamp bolts (9) evenly (torque below).

*SOFT SEAT: (Figure 2)*

- 6.5 Install one seat gasket (4) in the valve body (1) and one seat gasket (4) in the retainer ring (7).
- 6.6 Install the seat (3) into the valve. See figure 2 for correct ordination of the seat.
- 6.7 Install the seat ring (5) and retainer ring (7). Insert clamps (6 & 8) and torque clamp bolts (9) evenly (torque below).

*FIRE-SAFE: (Figure 3)*

- 6.8 Install one seat gasket (4) in the valve body (1) and one seat gasket (4) in the retainer ring (29).
- 6.9 Install the seat (3) into the valve. See figure 3 for correct ordination of the seat.
- 6.10 Install the seat ring (5), secondary seat gasket (27), secondary seat (28), and retainer ring (29). Insert clamps (6 & 8) and torque clamp bolts (9) evenly. See figure 3 for correct ordination of the secondary seat.

VALVE SIZE	TORQUE
2"-16"	96 IN*LBS
18"-24"	264 IN*LBS

*UPPER PACKING: (Figure 4)*

- 6.11 Carefully insert the packing (19) in the correct order. See figure 4 on how to insert packing. Slide gland (18) over stem.
- 6.12 Fully screw in studs (16). Set bracket (12) over the studs and shaft. Thread nuts (13) over studs leaving enough room to be able to lift the bracket and slide on packing gland flange (17). Insert and tighten bracket bolts (10) and washers (11). Tighten nuts (13).
- 6.13 Stack the belleville washers (15) over the studs in the order they came off of the valve. See figure 4 on the following page for proper order. Slide the cover (14) over the washers (15) and tighten nuts (13) evenly until the washers are fully compressed so that the cover (14) comes in contact with the packing gland flange (17). Be sure to gently build up the torque on both nuts so that the packing gets compressed evenly.

*LOWER PACKING:*

- 6.14 Insert packing (25) into the valve being careful not to damage the packing on the threads.
- 6.15 Tighten the bottom cover into the valve.

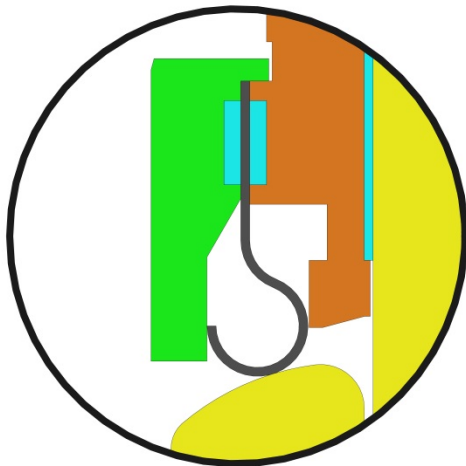
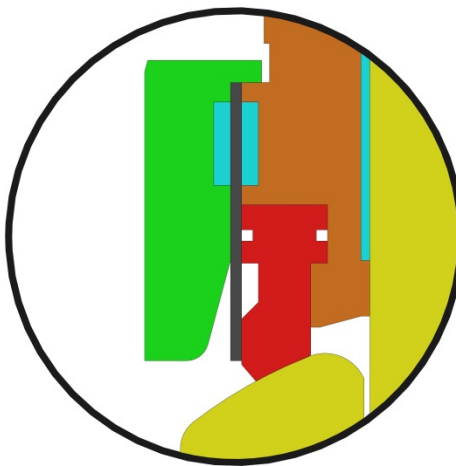
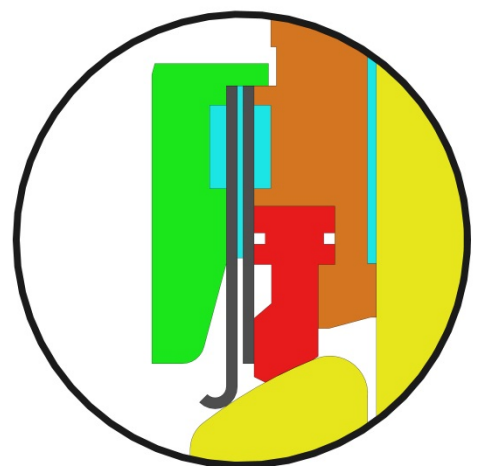
**(FIGURE 1)****(FIGURE 2)****(FIGURE 3)**

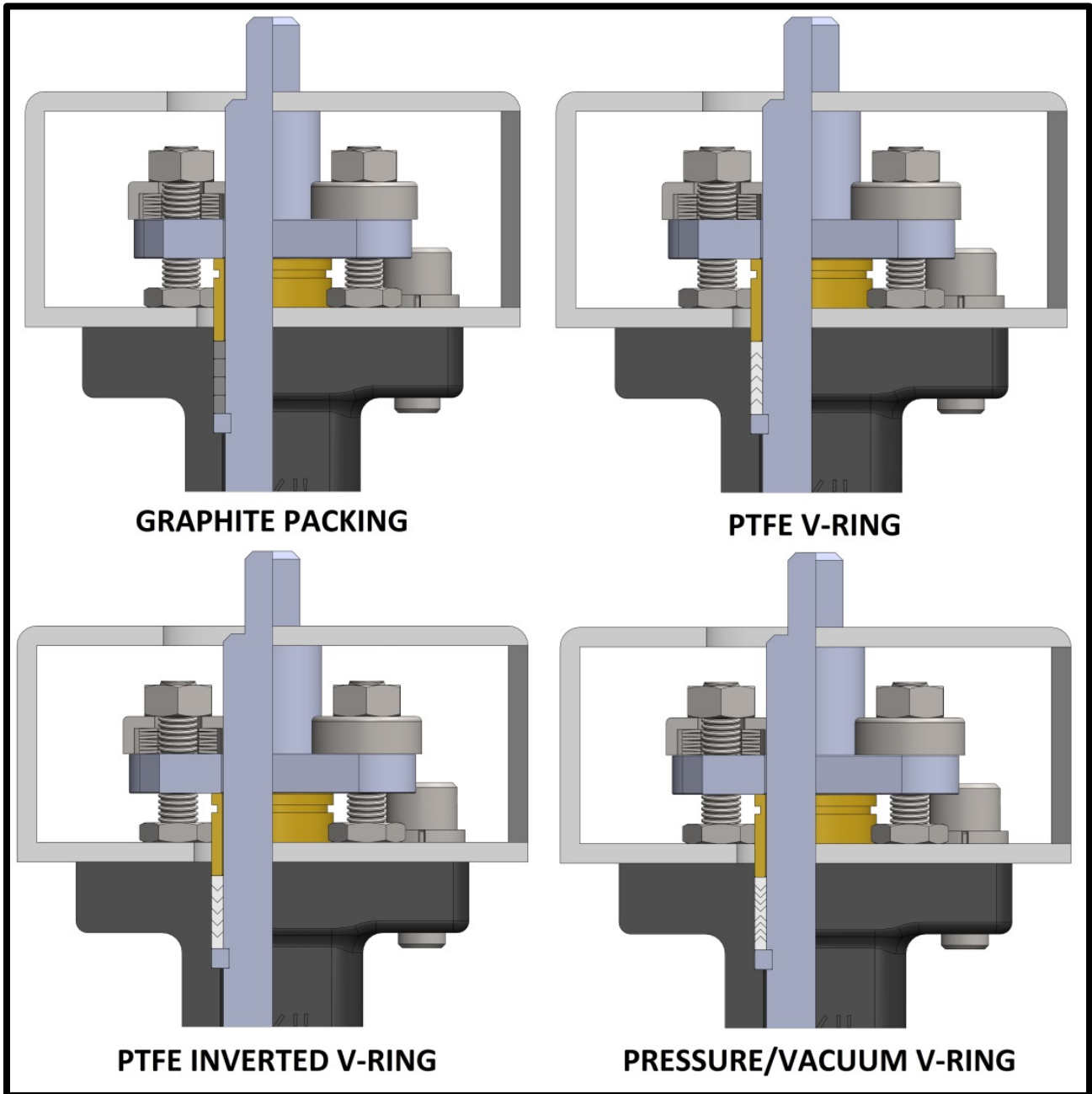

(FIGURE 4)

ITEM NO.	DESCRIPTION
1	BODY
3	SEAT SOFT SEAT
4	SEAT GASKET
5	SEAT RING SOFT SEAT
6	CLAMP PLATE (WAFER ONLY)
7	RETAINER RING
8	CLAMPS
9	CLAMP BOLTS
10	BRACKET BOLTS
11	BRACKET WASHER
12	BRACKET
13	PACKING GLAND NUTS
14	BELLEVILLE WASHER COVER
15	BELLEVILLE WASHERS
16	PACKING GLAND STUDS
17	PACKING GLAND FLANGE
18	GLAND
19	SHAFT UPPER PACKING
23	DISC PIN
25	SHAFT LOWER PACKING
26	BOTTOM COVER
27	SECONDARY SEAT GASKET
28	SECONDARY SEAT
29	RETAINER RING FIRE SAFE
30	METAL SEAT
31	RETAINER RING METAL SEAT
SEE CATALOG FOR FULL BILL OF MATERIAL	

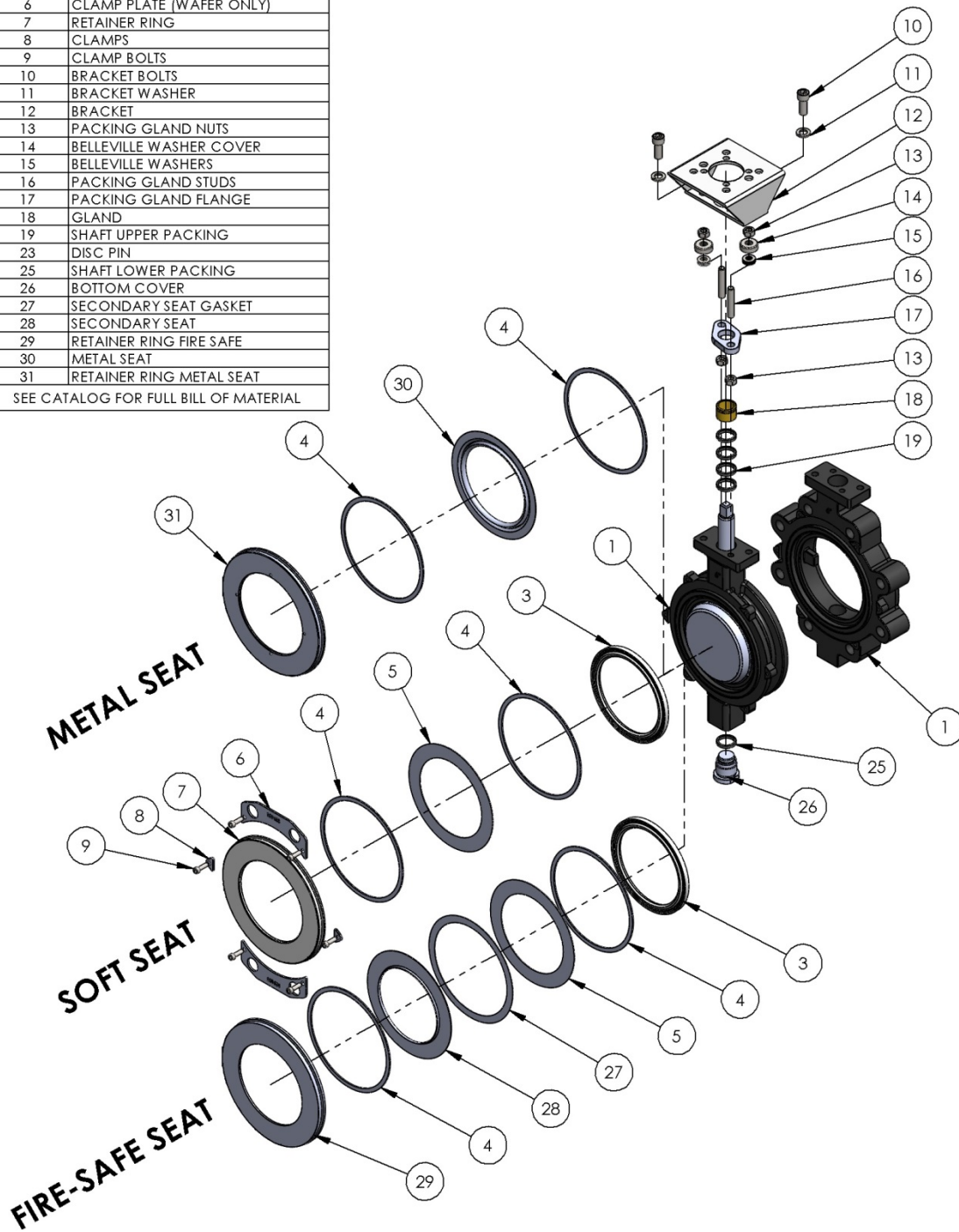



*A-T Controls product, when properly selected, is designed to perform its intended function safely during its useful life. However, the purchaser or user of A-T Controls products should be aware that A-T Controls products might be used in numerous applications under a wide variety of industrial service conditions. Although A-T Controls can provide general guidelines, it cannot provide specific data and warnings for all possible applications. The purchaser / user must therefore assume the ultimate responsibility for the proper sizing and selection, installation, operation, and maintenance of A-T Controls products. The user should read and understand the installation operation maintenance (IOM) instructions included with the product, and train its employees and contractors in the safe use of A-T Controls products in connection with the specific application.*

*While the information and specifications contained in this literature are believed to be accurate, they are supplied for informative purposes only. Because A-T Controls is continually improving and upgrading its product design, the specifications, dimensions and information contained in this literature are subject to change without notice. Should any question arise concerning these specifications, the purchaser/user should contact A-T Controls.*

For product specifications go to <http://download.a-tcontrols.com/>

A-T Controls, Inc. • 9955 International Boulevard, Cincinnati, OH 45246 • Phone: (513) 530-5175 • Fax: (513) 247-5462 • [www.a-tcontrols.com](http://www.a-tcontrols.com)